



D4.1 Material flow analysis results

29/08/2024

Partner(s): VITO, EFI

Author(s): Timokleia Orfanidou, Gustavo Ezequiez Martinez,
Giuseppe Cardellini

Prepared under contract from the European Commission and the United Kingdom Research and Innovation Council.

Grant agreement No. 101056755

EU Horizon Europe Research and Innovation Action

- Project acronym:** ForestPaths
- Project full title:** Co-designing Holistic Forest-based Policy Pathways for Climate Change Mitigation
- Project duration:** 01.09.2022 – 28.02.2027 (54 months)
- Project coordinator:** Dr. Hans Verkerk, European Forest Institute (EFI)
- Call:** HORIZON-CL5-2021-D1-01
- Deliverable title:** Material flow analysis results
- Deliverable n°:** D4.1
- WP responsible:** WP4
- Nature of the deliverable:** Report
- Dissemination level:** Public
- Lead partner:** VITO
- Recommended citation:** Orfanidou, T., Martinez, G. & Cardellini, G. (2024). ***D4.1 Material flow analysis results.*** ForestPaths project deliverable D4.1.
- Due date of deliverable:** August 2024
- Actual submission date:** Month n°

Deliverable status:

Version	Status	Date	Author(s)
1.0	Draft	26 July 2024	Timokleia Orfanidou (EFI), Gustavo Ezequiez Martinez (VITO), Giuseppe Cardellini (VITO)
2.0	Review	19 August 2024	Hans Verkerk (EFI), Aapo Rautiainen (LUKE)
3.0	Final	29 August 2024	Timokleia Orfanidou (EFI), Gustavo Ezequiez Martinez (VITO), Giuseppe Cardellini (VITO)

Table of contents

Key takeaway messages	4
Summary	4
List of abbreviations	6
List of Figures	7
List of Tables	7
1 Introduction	8
2 Material and Methods	9
2.1 Data source	12
2.1.1 Roundwood and semi-finished products	12
2.1.2 Added-value wood markets product and post-consumer wood	14
3 Results.....	17
4 Discussion	20
4.1 Main findings.....	20
4.2 Limitations	20
4.3 Next steps.....	21
5 References	22
6 Annex	24

Key takeaway messages

- In 2021, the 27 European Union member states (EU27) consumed 565 million cubic meters (Mm³) of roundwood in Solid Wood Equivalent (SWE). Of this total, 70% was allocated for materials, including sawmilling, panel production, and pulp manufacturing, while 30% was used directly for energy as fuelwood.
- In semi-finished product level, the sawmilling industry uses the majority (56%) of the wood entering the 1st transformation stage. Following from the wood pulp industry that uses 33% and lastly the wood panel industry that uses 11%.
- In 2nd transformation, paper and board is the largest consumer of added-value wood products (AWMs) at 137 Mm³ SWE, followed by the construction sector at 103 Mm³ SWE, indicating high demand in these end-use markets.
- In total, 88 Mm³ of wood remained in product use as stock for the year 2021 of which 10% is paper.
- European (and global) level data on final uses of wood are scattered and incomplete, necessitating new efforts on the monitoring of wood products and their trade.

Summary

This deliverable presents the results of a Material Flow Analysis (MFA) of wood use within the 27 European Union member states (EU27) for the year 2021. The MFA quantifies and analyzes the flow of wood through industrial systems and economies, providing a comprehensive understanding of stocks, flows, and transformations within defined system boundaries. This analysis tracks the flow of wood material through the entire supply chain, using Solid Wood Equivalent (SWE) as the unit of measurement. The data sources include FAOSTAT, EUROSTAT, INFRO, EPF, and other industry-specific databases.

In 2021, the EU27 consumed 565 million cubic meters solid wood equivalent (Mm³ SWE) of roundwood, with approximately 70% used for industrial purposes. The production of semi-finished products such as sawmilling, wood panels, and wood pulp utilized 466 Mm³ SWE, with 80% sourced from primary wood and 20% from secondary wood resources, including recovered post-consumer wood and residues. About 36% of the wood resources in this stage were not further transformed, comprising mostly residues and black liquor. The majority of wood consumed in added-value wood product markets (AWMs) transformed into paper and board (137 Mm³ SWE), followed by construction (103 Mm³ SWE). A smaller portion (3 Mm³ SWE) was used in textiles and chemicals, with 84 Mm³ SWE of wood and paper products remaining in use. A total of 326 Mm³ SWE is consumed for bioenergy production, with 45% derived from secondary wood.

Finally, the EU27 is a net exporter of 57 Mm³ SWE to the rest of the world (RoW), underscoring its significant role in the global wood market.

The robustness of the results is contingent on the quality and quantity of the underlying data, which has known limitations and discrepancies, especially in international statistics on wood products. Comparisons with previous studies show similar trends but highlight differences as a result of differences in methodologies and data sources.

D4.1 Material flow analysis results



This MFA provides a detailed and updated understanding of wood flows within the EU27, crucial for assessing the carbon storage in wood-based products, avoided emissions of wood use (i.e., substitution effects), and biodiversity impacts. Future work will refine these findings by incorporating better data where possible and extending the analysis to include additional countries (EU27+3).

List of abbreviations

Abbreviation	Explanation
AWM	Added-value wood product market
BIOENEU	Bioenergy Europe
CEPI	Confederation of the European Forest Industries
EPF	European Panel Federation
EU	European Union
JRC	Joint Research Centre of Europe
JWEE	Joint Wood Energy Inquiries
MFA	Material Flow Analysis
RWE	Roundwood Equivalent
SWE	Solid Wood Equivalent

List of Figures

Figure 1: System boundaries, transformation stages and products of the material flow analysis. Edge (arrows) represents flows of wood, nodes (boxes) products or products group when multiple products are clustered. In bold is indicated the name of the products or of the product group, in <i>italic</i> the products the groups consists of. Edges colors indicates data source, edge type the nature of the underlying data used.	11
Figure 3 Sankey diagram at EU27 level for the year 2021 (condensed version, for full resolution see Annex, Figure 6-2).....	19
Figure 4 Sankey diagram at EU27 level for the year 2021 (full resolution without unreported flows)	33
Figure 5 Sankey diagram at EU27 level for the year 2021 (full resolution with unreported flows).	34

List of Tables

Table 1 Key concepts introduced into the four major stages of the wood supply chain.....	9
Table 2 Main sources of data used for developing the material flows	12
Table 3 Example of products contained in each Added Value Market.....	14
Table 4 Data used to allocate semi-finished wood and paper products to the added-value wood product market (AWM).....	15
Table 5 Data used to allocate the added-value wood product market (AWM) to the Post-consumer wood categories. The category “Product stock” represent the share of that product category not flowing to another category and thus contributing to the stock for that specific product category (be it wood or paper in the Sankey diagram).....	16
Table 6 Structural and non-structural panels	24
Table 7 Wood panel shares from semi-finished wood products to AWMs. Used to calculate the shares of wood panels to AWMs	24
Table 8 Yield ratios for paper making and recovered paper	25
Table 9 Original FAOSTAT data grouping.....	25
Table 10 Conversion factors to SWE	26
Table 11 Wood flow amounts in EU27 for 2021 in Mm ³ SWE.....	27
Table 12 Results for 2021. Process inputs and outputs in Mm ³ SWE.....	30
Table 13 Our MFA results and JRC wood flows results for 2017 on Mm ³ SWE. Comparisons should be made with caution given that the methodologies used are not identical.	35

1 Introduction

WP4 develops enhanced tools, databases and methods to better estimate the mitigation potential and biodiversity impact of the European forest-based bioeconomy, including the substitution and carbon storage effect of forest-based material and energy products, with appropriate time dynamics. This deliverable reports on the work T4.1.2 that had the goal of performing a Material Flow Analysis of wood used related to the European forest-based sector for the present situation. The specific deliverable presents the results of the developed Material Flow Analysis (MFA) of wood use in EU27 for the year 2021.

In addition to developing the MFA of wood use in EU27, this work aims on increasing resolution of the wood MFA to include the Added-value Wood Product Markets (AWMs) (i.e., construction, chemicals, textiles, furniture and others) and post-consumer wood (end-of-life treatment) with the goal of connecting it to an LCA for calculating substitution factors. A substitution factor (or displacement factor) describes how much greenhouse gas emissions would be avoided if a wood-based product is used instead of another product to perform the same function (Leskinen et al., 2018). Increasing the resolution to include AWM aids in delivering data on the amount of wood products consumed by specific AWMs (i.e., $x \text{ Mm}^3$ in Construction). These AWMs can then be modelled as a basket of products in LCA (i.e., for construction: walls, roofs, columns and others both for forest-based and counterpart products), and provide a more accurate picture on the substitution potentials of the European forest-based sector, and thus, its contribution to climate change mitigation.

Wood flows have been mapped for the EU (Cazzaniga et al., 2022; Mantau, 2012) and the latest update by JRC is for 2017. The JRC wood flows provide information up to the semi-finished wood product level without going further down the supply chain to AWMs and end-of-life. Thus, the findings of this report are a first step towards disaggregating EU wood flows, and they go a step further by including the AWM and post-consumer wood treatment.

2 Material and Methods

MFA quantifies and analyses the flow of materials through industrial systems and economies. It provides a comprehensive understanding of the stocks, flows, and transformations of materials within a defined system boundary¹ (Brunner & Rechberger, 2004). The developed MFA tracks the flow of wood material between economic activities that were grouped into the four major stages of the wood supply chain (Figure 1).

Table 1 Key concepts introduced into the four major stages of the wood supply chain

Wood transformation stage	Description
Roundwood	Roundwood refers to the raw wood material that is harvested directly from trees in the form of logs, trunks, branches, or other round sections. This is the initial stage in the wood product lifecycle, where the wood is still in its most natural and unprocessed state.
Semi-finished products (1st Transformation)	Semi-finished products refer to wood materials that have undergone primary processing from roundwood. This stage is called the "1st transformation" and involves converting raw logs into usable materials such as sawn timber (lumber), veneers, plywood, particleboard, or wood pulp.
Added-value Wood Product Markets	Added-value wood product markets refer to products that have undergone further processing or finishing after the initial transformation and categorized under their final market (i.e., construction, paper and packaging, textiles and chemicals, furniture and others). These markets are crucial in the wood industry as they represent the end stage of the production process, where wood products reach consumers and are used.
Post-consumer wood (End-of-life)	Post-consumer wood refers to wood materials that have reached the end of their useful life. This stage is known as the "end-of-life" phase in product lifecycle. Post-consumer wood can be managed in several ways: it can be recycled into new products, reused in its current form, or disposed of through incineration or landfilling.

The geographical scope and the resolution of the analysis is the EU27. For each of the tracked products, the trade between EU27 and the rest of the world (RoW) has also been considered. Solid Wood Equivalent (SWE) under bark was used as unit to track the flow of wood over its entire

¹ A system boundary defines the scope of a system for analysis or study. It distinguishes between what is contained within the system (i.e., the components, processes, inputs, and outputs) and what is outside of it, which is considered part of the environment or external factors.

supply chain since it allows to track wood consumption consistently across its different uses while it also provides a standardised way to compare different wood products which may come in different forms, densities, processing or moisture content.

In this context, SWE provides the green volume of wood, prior to any shrinkage e.g. the amount of solid wood fibre contained in the product. As for the difference between roundwood equivalents (RWE) and SWE, UNECE & FAO, 2010 define m^3 RWE as the total roundwood input needed to produce a semi-finished product, including residual materials and potential production losses. Contrary, the m^3 SWE of a semi-finished product only measures the volume of solid biomass before shrinkage. Residues that may generate during production processes, such as sawmill by-products from sawnwood production, are not included in the m^3 SWE for semi-finished products. However, residual wood volumes were considered, but separately in the MFA presented in this report.

The conversion factors applied in this study can be found in Annex II. Data was collected from different sources including wood statistics databases, reports and other available resources (see section 2). Data was processed and analysed with the software library [aiphoria](#) (see Deliverable 4.2) and all the data used are Annexed.

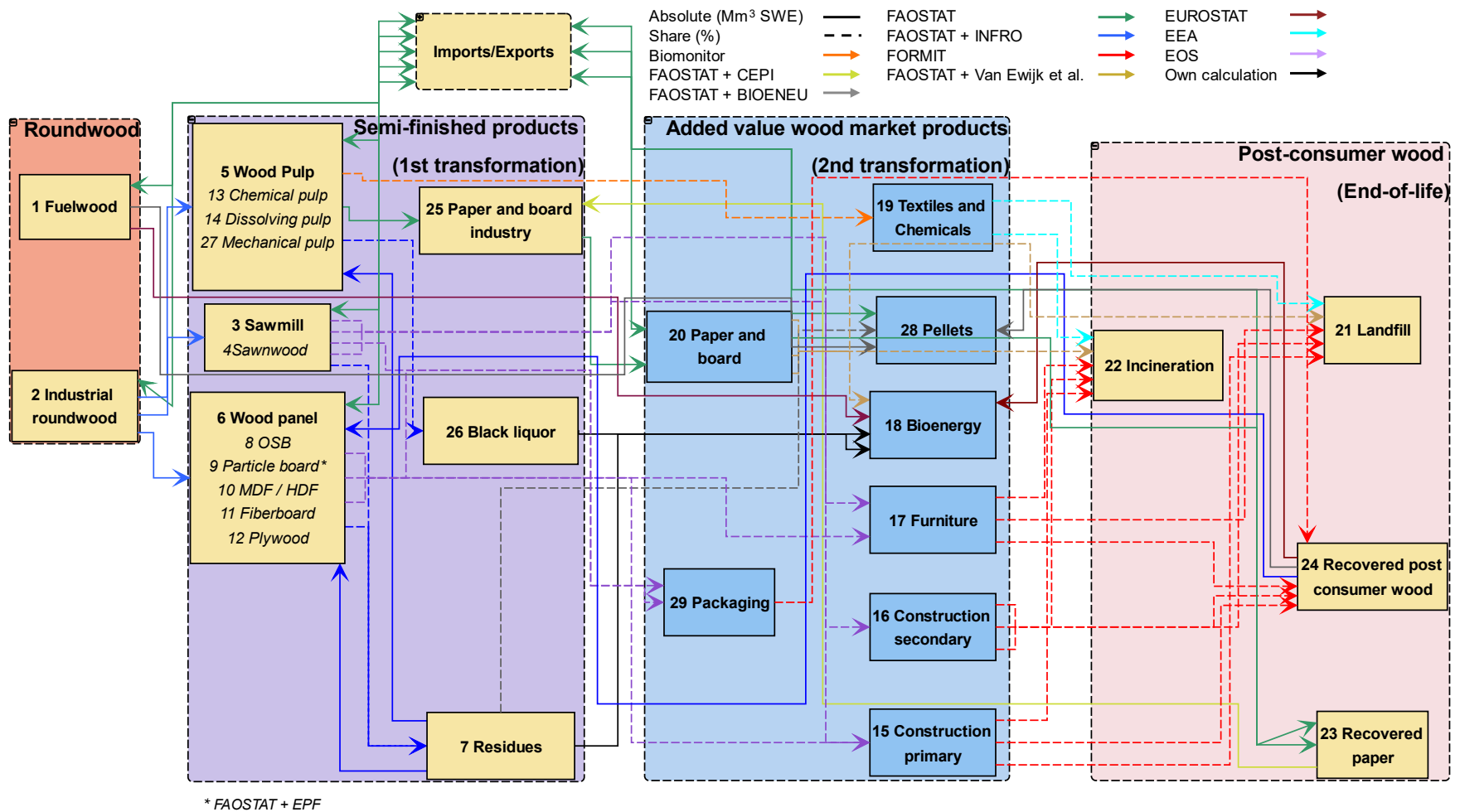

Figure 1: System boundaries, transformation stages and products of the material flow analysis. Edge (arrows) represents flows of wood, nodes (boxes) products or products group when multiple products are clustered. In bold is indicated the name of the products or of the product group, in italic the products the groups consists of. Edges colors indicates data source, edge type the nature of the underlying data used.

2.1 Data source

2.1.1 Roundwood and semi-finished products

The apparent consumption in EU27 as well as the trade between EU27 and the RoW for roundwood and semi-finished products were obtained from the FAOSTAT database (cfr. Table 2). FAOSTAT data are originally reported in m³ or tonnes and were converted into m³ SWE using the conversion factors reported in Table 2 and in Annex (i.e., for sawnwood by multiplying the FAOSTAT data with the respective conversion factor). Apparent consumption is defined as production + imports - exports of the product and represents the volume of forest products consumed in EU27 considering the local production and the net trade (imports and exports). Apparent consumption was preferred as objective of this work is to track the actual flow of forest products, usage in Added-value Wood Markets (AWMs) and disposal when and where they occur (within the EU27 boundaries). The input-output coefficient from INFRO were used to estimate the amount of industrial by-products (i.e. black liquor, and residues in Figure 1) generated in the 1st transformation stage as well as the amount and type of wood (roundwood, residues or recovered post consumer wood in Figure 1) used in the same stage. INFRO coefficients report on the amount of raw material input needed (i.e for sawmilling by multiplying sawlog FAOSTAT volume with the corresponding input coefficient). Similarly, output coefficients used to provide the amount of industrial by-products. The only exception is for particle board, for which EPF input coefficients were used (EPF, 2020). In some cases (i.e., industrial roundwood) there is an imbalance on the inputs and outputs where unreported virtual flows have created to balance out our system (for unreported virtual flows, see Annex, Table 11, Table 12, and Figure 3 denoted as VP_x where x is the unreported flows and process).

Table 2 Main sources of data used for developing the material flows

Source	Data used	Reference
FAOSTAT	Production, imports, exports amounts of forest products	(FAO, 2020) Forestry Production and Trade https://www.fao.org/faostat/en/#data/FO
EUROSTAT	Production of fuelwood, recovered post consumer wood	(Eurostat, 2023) Supply of biomass - annual data. Energy statistics https://ec.europa.eu/eurostat/databrowser/view/nrg_cb_bm/default/table?lang=en
INFRO	Input (raw material used) / output (residues, black liquor, recovered post consumer wood) coefficients for wood products industry.	(EC-JRC, 2010) Input and output coefficients for the wood-based industry. (INFRO) http://data.europa.eu/89h/a1f94d36-748d-48ef-81bdf936c64e5800
BIOENERGY EUROPE	Input coefficients for pellets	(Bioenergy Europe, 2019) https://saf.org.ua/wp-content/uploads/2019/12/pellets-bioenergy-europe-report-2019-brief.pdf

EPF	Input (raw material used) for particle board	(EPF, 2020) https://europanel.org/wp-content/uploads/2020/12/EPF-Advocacy-Leaflet.pdf
Van Ewijk et al.	Paper making yield applied in paper and board and fraction of paper and board to end of life and stock	(Van Ewijk et al., 2018)
CEPI	Recovered paper processing yield	(CEPI, 2023) 2022-Key-Statistics-FINAL.pdf (cepi.org)
EOS	Wood Panel distribution to AWM	(EOS, 2023) Annual report of the European Sawmill Industry 2022-2023. eos-oes.eu/wp-content/uploads/2023/06/eos-annual-report-20222023.pdf
FORMIT	AWM distribution to end of life	(Valada et al., 2016) Deliverable 3.2 LCA and mitigation potential from forest products.
Biomonitor	Dissolving pulp distribution to AWM	(van Leeuwen et al., 2022)
EEA	End Of Life fate of Textiles and Chemicals.	(European Parliament, 2020) The impact of textile production and waste on the environment (infographics). https://www.europarl.europa.eu/topics/en/article/20201208STO93327/the-impact-of-textile-production-and-waste-on-the-environment-infographics
Mantau/JRC	Conversion factors from m ³ or tonnes to m ³ SWE	(EC-JRC, 2010) Input and output coefficients for the wood-based industry. (INFRO) http://data.europa.eu/89h/a1f94d36-748d-48ef-81bdf936c64e5800
FAO		(FAO. ITTO. United Nations, 2020)(FAO. ITTO. United Nations, 2020) Forest Product conversion factors. https://doi.org/10.4060/ca7952en
JWEE		(JWEE, 2021)
Jochem et al.		(Jochem et al., 2021)

2.1.2 Added-value wood markets product and post-consumer wood

The main end-uses of wood were estimated by allocating the amount of wood contained into the semi-finished wood products (in Mm³ SWE) to the different AWMs by using the output shares reported in Table 4. The list of AWMs (Table 3) has been developed considering their present and future market share and taking also into account the feedback provided by the stakeholders in ForestPaths' Policy Lab 1 as well as the finding by Kunttu et al., (2024). The end of life fate of the AWMs was estimated by allocating their amount to the different post-consumer wood categories using the output shares reported in Table 5, the amount of recovered paper for Paper and board is retrieved from FAOSTAT, where a yield ratio is applied for processing recovered paper (CEPI, 2023) to determine the usable recovered fiber.

Table 3 Example of products contained in each Added Value Market

Added Value Market	Wood products
Construction, Structural	Floor, CLT wall, external wall, roof frame
Construction, Non Structural	Laminare floor, window, insulation board
Furniture	Kitchen cabinet, sofa, bed, shelf
Bionergy	Pellets, heat, electricity, black liquor
Chemicals and Textiles	Lignin-based adhesives, lyocell, viscose
Paper and Packaging	Beverage carton container, graphic paper
Wood Packaging	Pallets, wood boxes

This approach implicitly assumes that there is no trade of secondary products from EU to RoW and that thus all the first transformation products produced in EU27 are consumed in the same region. The grouping of the original FAOSTAT data can be found in Annex, Table 9. The data in Table 4 and Table 5 are not statistical data like the FAOSTAT data reported each year, but rather data gathered from multiple bibliographical sources to connect semi-finished wood products to AWMs and then to post-consumer wood categories. These links are represented by the Sankey diagrams in Annex, Figure 3 and Figure 4. Figure 2 also provides insights on the MFA system but it excludes some information given it provides a condensed alternative of the Sankey diagram.

Table 4 Data used to allocate semi-finished wood and paper products to the added-value wood product market (AWM)

Semi-finished products (from)	AWM (to)	Output shares (%)	Source
Particle board	Furniture	63.7	(EC-JRC, 2010; EOS, 2014, 2023)
	Construction_secondary	29.3	
	Packaging	2	
	Residues	5	
MDF HDF	Furniture	58.3	
	Construction_secondary	29.1	
	Packaging	7.6	
	Residues	5	
OSB	Furniture	3.1	
	Construction_primary	85.6	
	Packaging	6.3	
	Others	8.55	
	Residues	5	
Fiberboard	Furniture	13.3	
	Construction_secondary	60	
	Packaging	21.7	
	Residues	5	
Plywood	Furniture	13.5	
	Construction_primary	23.1	
	Packaging	4.6	
	Residues	55	
Sawnwood	Construction_primary	65.1	
	Construction_secondary	9.1	
	Residues	0.4	
	Packaging	21.2	
	Furniture	4.2	
Chemical pulp	Paper and board industry	47	(EC-JRC, 2010; FAO, 2020; van Leeuwen et al., 2022)
	Black liquor	53	
Dissolving pulp	Textiles and Chemicals	38	

	Black liquor	62
Mechanical pulp	Paper and board industry	96.4
	Black liquor	3.6

Table 5 Data used to allocate the added-value wood product market (AWM) to the Post-consumer wood categories. The category “Product stock” represent the share of that product category not flowing to another category and thus contributing to the stock for that specific product category (be it wood or paper in the Sankey diagram).

AWM (from)	Post-consumer wood (to)	Output shares (%)	Source
Construction primary	Landfill	33	Formit. (2016) Deliverable 3.2 LCA and mitigation potential from forest products.
	Recovered post consumer wood	20	
	Incineration	5	
	Product stock	42	
Construction secondary	Landfill	33	
	Recovered post consumer wood	20	
	Incineration	5	
	Product stock	42	
Furniture	Landfill	33	
	Recovered post consumer wood	20	
	Incineration	5	
	Product stock	42	
Packaging	Recovered post consumer wood	33.5	
	Product stock	66.5	
Textiles Chemicals	Landfill	33	(European Parliament, 2020)
	Incineration	67	
Paper and board ²	Bioenergy	5	(Van Ewijk et al., 2018)
	Landfill	82.5	
	Product stock	9	

² For recycling of Paper and board FAOSTAT data are used as explained above in this section. The shares in this table refer to the rest of Paper and board that is not recycled.

3 Results

Roundwood to material uses

- The results of the MFA of wood use in the EU27 for the year 2021 can be seen in the Sankey diagram of Figure 2 and in Annex in more detail in Figure 3 and Figure 4. Of the 565 Mm³ SWE of roundwood consumed EU27 in 2021 around 70% is allocated for material uses (Industrial roundwood). Out of the total 565 Mm³ SWE, around 4% or 19.9 Mm³ SWE is not specifically allocated anywhere according to the available data, and thus representing unreported flows. In the Sankey diagram this unreported flow is depicted as an unassigned flow originating from industrial roundwood.

Semi-finished products

- The production of semi-finished products (sawmilling, wood panels and wood pulp) in EU27 consumes a total 466 Mm³ SWE (including recovered post consumer wood and residues), out of which 372 Mm³ SWE (80%) is from primary wood.
- During this stage 94 Mm³ SWE of secondary wood resources (residues and recovered post consumer wood) are used, as inputs to panel industry and wood pulp which is around 20% of the total inputs.
- The sawmilling industry consumes the majority (56% or 208 Mm³ SWE) of the wood entering the 1st transformation stage, all of it in the form of virgin wood. Following from the wood pulp industry that consumes 33% or 121 Mm³ SWE and lastly the wood panel industry that consumes 11% or 42.57 Mm³.
- Outputs from sawmilling, wood panels and wood pulp that do not end up in AWMs are 167 Mm³ SWE which is the 36% of the total wood resource consumed (including recovered post consumer wood and residues). Out of the 167 Mm³ SWE, 54% is residues and 46% black liquor.

Consuming markets – Added Value Wood Product Markets (AWMs)

- The main consuming markets are paper and board (137 Mm³ SWE), followed by the construction sector (103 Mm³ SWE), furniture (47.7 Mm³ SWE) and packaging (24.8 Mm³ SWE).
- The textiles and chemicals sector used the least amount of wood (3 Mm³ SWE).
- In total, 80 Mm³ of wood products and 4 Mm³ of paper products remained in use, contributing to the wood products stock pool.

Bioenergy

- Approximately 30% of roundwood is used directly for energy application (i.e., fuelwood).
- A total of 326 Mm³ SWE are consumed to produce bioenergy, including pellets. Of this, 54% came from fuelwood, 38% from secondary wood sources (including 24% black liquor, 8% recovered post-consumer wood, and 6% industry residues), 7% from additional recovered post-consumer wood, and 1% from imports.
- Pellets accounted for 50.6 Mm³ SWE, with 43% originating from unreported sources. The remaining portion was sourced from 36% residues, 13% fuelwood, 6% imports, and 2% recovered post-consumer wood.

Post consumer wood – End of life

- In total, 12 Mm³ SWE end up in incineration without energy recovery, and 81 Mm³ in landfill.
- In total, 49 Mm³ SWE are utilized as recovered post consumer wood of which almost equally is then used in the panel industry and bioenergy as secondary material source.

Net trade

The EU27 trade balance shows that the EU27 is a net-exporter, with approximately net exports of 57 Mm³ SWE, out of a gross export volume of 77 Mm³ SWE.

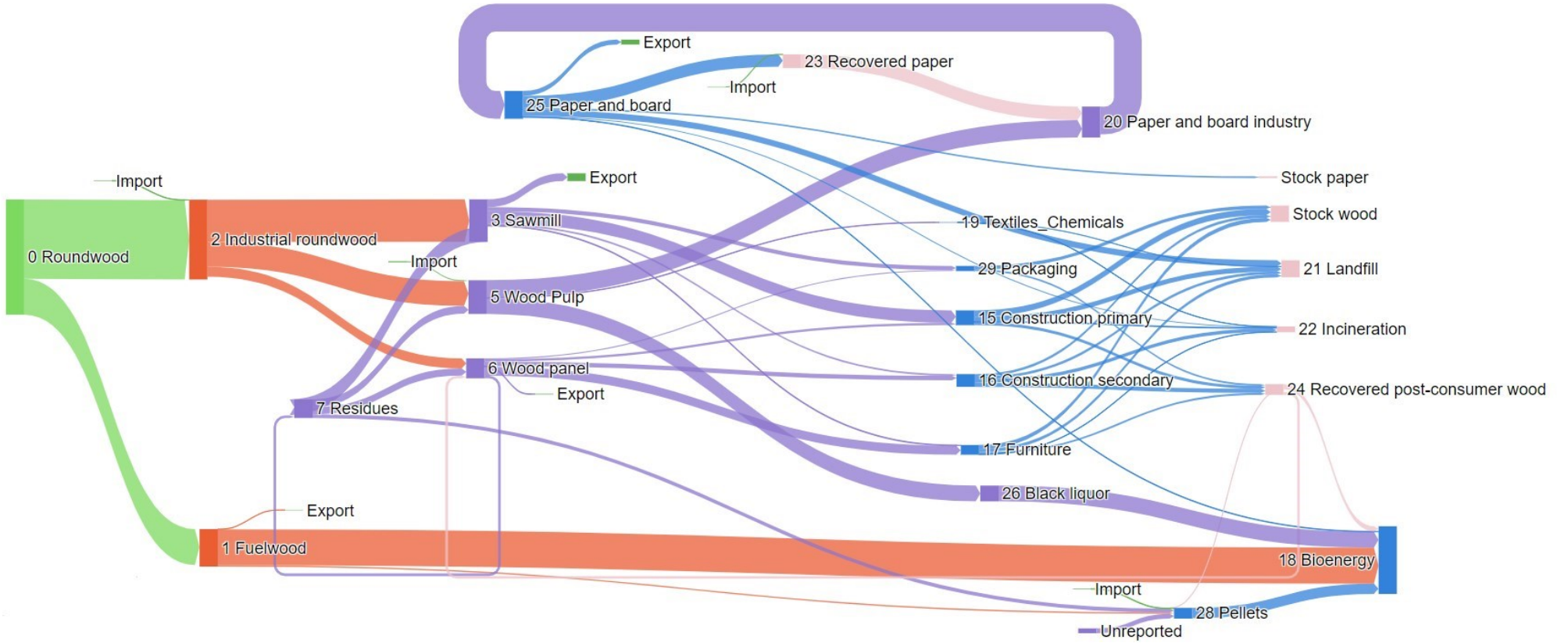

Figure 2 Sankey diagram at EU27 level for the year 2021 (condensed version, for full resolution see Annex, Figure 4).

4 Discussion

4.1 Main findings

In this study we presented the findings of the developed MFA of wood use in EU27 for the year 2021. According to the findings, three industries in the EU27 consume the majority of wood: sawmilling, wood panels, and wood pulp. Residues, recovered post consumer wood, and industrial by products all play an important role in wood product manufacturing. At the same time, a large amount of roundwood is directly used for energy, leaving room for potential shifts between material and energy uses. From the three main industries then wood products are utilized by seven AWMs: construction primary and secondary, textiles and chemicals, furniture, wood packaging, paper and packaging and bioenergy. Paper and packing, construction and furniture are the larger end users of finished wood products. When it comes to end of life, wood products are either incinerated without energy recovery, landfilled or utilized as recovered post-consumed wood or recovered paper. The EU forest industry has an orientation of exporting wood products.

In regards to data, data on bioenergy is more difficult to collect and less accurate than data on semi-finished wood products, so EUROSTAT data were preferred over FAOSTAT data for fuelwood. At the same time, collecting data on AWMs requires substantial resources, potentially necessitating the establishment of efforts to collect data on the final uses of wood products rather than just the semi-finished product level.

4.2 Limitations

The robustness of our results are obviously highly dependent on the quantity and quality of the underlying data used. The limited availability of data about the use of wood is a known issue (see e.g. Camia et al., 2020). International statistics on wood products production and trade often exhibit issues and discrepancies, sometimes also significant, as previously highlighted from various authors. For instance, Buongiorno, 2018 identified substantial inconsistencies in FAOSTAT data, estimating that from 2013 to 2015, industrial roundwood consumption was under-reported by a total of 368 million m³ across 57 countries and over-reported by 16 million m³ in 44 countries. The primary source of these discrepancies was found to be in production statistics rather than trade. (Kallio & Solberg, 2018) conducted an analysis on the reliability of international statistics regarding the production and trade of forest products. They used simple tests and linear programming to examine the consistency of data on production, imports, and export volumes of wood. Notably, they discovered that data related to the supply of wood chips and particles are unreliable in many countries. Also Rougieux et al., 2017 extensively studied the issue of trade flow data quality, identifying also the common reasons for discrepancies in trade flow data.

The data from FORMIT, EOS and INFRO are, in some case, relatively old (2010), another limitations to be acknowledged together with the lack of consideration of the trade of secondary products. For the Textiles and Chemicals, we assumed that for the post-use fate the products that come out of use are either incinerated or landfilled, in reality some of the e.g. textiles are exported outside the EU (European Parliament, 2020). For the paper and board sector data FAOSTAT

statistics in combination with the data provided by Van Ewijk et al. (2018) were preferred given that CEPI³ statistics include EU27+3 while our analysis includes EU27 countries.

For conducting the analysis, we followed the (apparent) consumption approach which accounts for all the products consumed within the studied system boundaries (EU27). The drawback of this approach is that makes the origin of imported wood products difficult to track and may have some implications on wood trade policies in some countries. However, this choice is justified given the goal of this study is later on to conduct scenarios in wood utilization on the demand side and to point out sectors with e.g., higher carbon stock potentials.

4.3 Next steps

As a next step, our analysis will extend to EU27+3 where the CEPI data will become more relevant to use. At EU level, there are two main other works looking into the EU wood flows from (Mantau et al., 2010), and the Sankey diagrams of wood biomass flows in the EU produced by JRC (Cazzaniga et al., 2022). In both cases, the resolution of the wood flows is up to (Cazzaniga et al., 2022) semi-finished product level for all sectors besides paper industry given that the amounts are known from FAOSTAT. Table 13 in the Annex compares our results with those from JRC (2017) and Mantau (2010). As anticipated, our results do not differ significantly from JRC's results. This does not come as a surprise given that we have partially relied on the coefficients and other similar data with JRC.

Our analysis enable a very crucial aspect for understanding market dynamics which is the actual utilization of wood products by the AWMs. This advancement allows for an improved understanding of the role of wood products as it allows for tracking how much and from which AWMs wood resources are consumed. As a next step, this methodology will allow to track in which AWMs wood products are stored, for how long, and when they will be available as post-consumer wood in the EU27. This will enable the understanding of the role of wood products as carbon sinks. Besides, the information on the utilization of wood products by the AWMs, will enable us to provide inputs to upscale the substitution factors to market level to assess the overall mitigation potential.

Despite the aforementioned shortcomings, compared to previous work in this domain, our analysis includes the further processing of semi-finished wood products into to their final end uses and the most recent available data have been used. These advances not only improve the representation of the different transformation steps in the European wood sector but are also crucial to enable the coherent translation of the EFI-GTM and IMAGE modelled market implications of the alternative pathways/scenarios into their carbon storage, substitution, and biodiversity impacts.

³ Confederation of the European Paper Industries

5 References

- Bioenergy Europe. (2019). *Policy Brief Pellet*. <https://saf.org.ua/wp-content/uploads/2019/12/pellets-bioenergy-europe-report-2019-brief.pdf>
- Brunner, P. H., & Rechberger, H. (2004). Practical handbook of material flow analysis. *The International Journal of Life Cycle Assessment*, 9(5), 337–338. <https://doi.org/10.1007/BF02979426>
- Buongiorno, J. (2018). On the accuracy of international forest product statistics. *Forestry: An International Journal of Forest Research*, 91(5), 541–551. <https://doi.org/10.1093/forestry/cpy025>
- Camia, A., J. Giuntoli, J., Jonsson, R., Robert, N., Cazzaniga, N., Jasinevičius, G., Avitabile, G., Grassi, G., Barredo, V., & Mubareka, S. (2020). *The use of woody biomass for energy production in the EU*. <https://doi.org/10.2760/831621>
- Cazzaniga, N., Jasinevičius, G., & Mubareka, S. (2022). *Sankey diagrams of woody biomass flows in the EU - 2021 release*. <https://publications.jrc.ec.europa.eu/repository/handle/JRC127989>
- CEPI. (2023). *Cepi Key Statistics 2022*. <https://www.cepi.org/wp-content/uploads/2023/07/2022-Key-Statistics-FINAL.pdf>
- EC-JRC. (2010). *Input and output coefficients for the wood-based industry*. European Commission, Joint Research Centre (JRC) [Dataset]. <https://data.jrc.ec.europa.eu/dataset/a1f94d36-748d-48ef-81bd-f936c64e5800>
- EOS. (2014). *Economic importance of the European sawmill industry and impacts within the forest-based and other related sectors*.
- EOS. (2022). *Annual Report of the European Sawmill Industry 2021 – 2022*. https://eos-oes.eu/wp-content/uploads/2023/04/eos-annual-report-2021-2022_web.pdf
- EOS. (2023). *Annual report of the European Sawmill Industry 2022-2023*. <https://eos-oes.eu/wp-content/uploads/2023/06/eos-annual-report-20222023.pdf>
- EPF. (2020). *THE WOOD-BASED PANELS INDUSTRY*. <https://europanel.org/wp-content/uploads/2020/12/EPF-Advocacy-Leaflet.pdf>
- European Parliament. (2020). *The impact of textile production and waste on the environment (infographics)*. <https://www.europarl.europa.eu/topics/en/article/20201208STO93327/the-impact-of-textile-production-and-waste-on-the-environment-infographics>
- Eurostat. (2023). *Supply of biomass - annual data*. *Energy statistics*. https://doi.org/https://doi.org/10.2908/NRG_CB_BM
- FAO. (2020, July). *Forest product statistics*. FAOSTAT-Forestry Database.
- FAO. ITTO. United Nations. (2020). *Forest product conversion factors*. FAO, ITTO and United Nations. <https://doi.org/10.4060/ca7952en>
- Jochem, D., Bösch, M., Weimar, H., & Dieter, M. (2021). National wood fiber balances for the pulp and paper sector: An approach to supplement international forest products statistics. *Forest Policy and Economics*, 131, 102540. <https://doi.org/10.1016/j.forpol.2021.102540>

- JWEE. (2021). *UNECE/FAO FORESTRY AND TIMBER SECTION JOINT WOOD ENERGY ENQUIRY v 9.02*. <https://unece.org/forests/joint-wood-energy-enquiry>
- Kallio, A., & Solberg, B. (2018). On the Reliability of International Forest Sector Statistics: Problems and Needs for Improvements. *Forests*, 9(7), 407. <https://doi.org/10.3390/f9070407>
- Kunttu, J., Hurmekoski, E., Zarkaliou, A., Tasios, N., Tsiropoulos, I., Lauri, P., & Fulvio, di F. (2024). *D5.1 Market scenarios for selected material uses of wood and bioenergy in the EU*.
- Leskinen, P., Cardellini, G., González García, S., Hurmekoski, E., Sathre, R., Seppälä, J., Smyth, C. E., Stern, T., & Verkerk, H. (2018). Substitution effects of wood-based products in climate change mitigation. *From Science to Policy*, 7(November), 28. <https://www.efi.int/publications-bank/substitution-effects-wood-based-products-climate-change-mitigation>
- Mantau, U., Saal, U., Prins, K., Steierer, F., Lindner, M., Verkerk, H., Eggers, J., Leek, N., Oldenburger, J., Asikainen, A., & Anttila, P. (2010). EUwood - Real potential for changes in growth and use of EU forests. Final report. In *EUwood* (Issue June). https://unece.org/fileadmin/DAM/timber/meetings/20110321/euwood_final_report.pdf
- Mantau, U. (2012). *Wood flow analysis Europe 2010*. http://www.cepi.org/wood_flows_in_Europe/
- Rougieux, P., Van Brusselen, J., Lovrić, M., Kiljunen, J., Varis, S., & Zudin, S. (2017). *The Forest Products Trade Flow Database – A reproducible method and tool to support the analysis of international forest products trade*. *EFI Technical Report 100*.
- UNECE, & FAO. (2010). *Forest Product Conversion Factors for the UNECE Region*. *Geneva Timber and Forest Discussion Paper 49*.
- UNECE/FAO. (2022). *Forest Products Annual Market Review 2021-2022*. https://unece.org/sites/default/files/2023-02/2228765E_Inside_final_signa_red.pdf
- Valada, T., Cardellini, G., Muys, B., Lamoulie, J., Privat, F., Cornillier, C., & Verbist, B. (2016). *Deliverable 3.2 LCA and mitigation potential from forest products*.
- Van Ewijk, S., Stegemann, J. A., & Ekins, P. (2018). Global Life Cycle Paper Flows, Recycling Metrics, and Material Efficiency. *Journal of Industrial Ecology*, 22(4), 686–693. <https://doi.org/10.1111/jiec.12613>
- van Leeuwen, M., de Beus, N., Godeschalk, F., Gonzalez-Martinez, A., Hark, N., Lovrić, M., Moiseyev, A., Rossi Cervi, W., Sturm, V., Verhoog, D., & Hans Verkerk. (2022). *Biomonitor D5.2: Report on the development of BioMAT and EFI-GTM for medium-term projections and simulations for bio-based products*. https://biomonitor.eu/wp-content/uploads/2022/10/BioMonitor_D5.2_FutureMarkets_28Sep22-.pdf

6 Annex

Input data assumptions, conversion factors, and MFA flows and processes

Table 6 Structural and non-structural panels

Structural Panels	Non-structural panels	Source
Plywood made from cross-laminated veneer, and oriented strandboard – OSB – made from wood strands bonded together	<p>Particle board and fibreboard</p> <p>Fibreboard is the term used for various types of panels made of wood fibre, including:</p> <p>high-density fibreboard (HDF) and medium-density fibreboard (MDF), which are both included in the MDF category here;</p> <p>wet-process hardboard, which is similar in density to HDF but made with a wet process;</p> <p>and low-density fibreboard, which comprises products such as insulation board, “other board” and softboard (both ridged and flexible).</p>	(UNECE/FAO, 2022)

Table 7 Wood panel shares from semi-finished wood products to AWMs. Used to calculate the shares of wood panels to AWMs

Wood panel type	Total production, Mm ³	Furniture	Construction primary	Construction secondary	Packaging	Other (excluded from our study)	Source
Particleboard	30.7	63%	-	29%	2%	6%	(EOS, 2022)
MDF	12.1	54%	-	27%	7%	12%	
OSB	7	3%	82%		6%	9%	
Fibreboard		8%	-	36%	13%	43%	
Plywood	2.8	30%	40%		8%	22%	

Table 8 Yield ratios for paper making and recovered paper

Process	Value	Source
Paper and board industry	0.95	(Van Ewijk et al., 2018)
Recovered paper	0.90	(CEPI, 2023)

Table 9 Original FAOSTAT data grouping.

FAOSTAT definitions can be found here: <https://www.fao.org/forestry-fao/36058-0902b3c041384fd87f2451da2bb9237.pdf>

Element	Item code	Source
Fuelwood	1627,1628,1629	(FAO, 2020)
Industrial Roundwood	1601,1602,1603,1604,1623,1626,1651,1657,1670	
Sawnwood	1632,1633	
Wood-based Panels	1634,1640	
	1606	
	1648	
	1697	
	1647,1650	
Wood Pulp	1662,1663,1686,1660,1661	
	1667	
	1654,1655,1685	
Paper and packaging	1612,1615,1616,1617,1618,1621,1622,1671,1676,1683	
Recovered Paper	1669	
Post consumer wood	1600	
Wood Chips	1619	
Wood Residues	1620	
Pellets	1693,1694	

Table 10 Conversion factors to SWE

Item	Item code	Conversion factor	Source
Cartonboard	1618	1.726	(Jochem et al., 2021)
Case materials	1617	1.747	
Household and sanitary papers	1676	1.895	
Newsprint	1671	1.653	
Other paper and paperboard n.e.s. (not elsewhere specified)	1683	1.453	
Other papers mainly for packaging	1622	1.642	
Printing and writing papers, uncoated, mechanical	1612	1.368	
Printing and writing papers, uncoated, wood free	1615	1.474	
Printing and writing papers, coated	1616	1.211	
Wrapping papers	1621	1.895	
Recovered Paper	1669	1.526	
Wood chips and particles	1619	2.43	(FAO. ITTO. United Nations, 2020)
OSB	1606	1.68	
MDF/HDF	1648	1.79	
Sawnwood, coniferous	1632	1.828148148	(EC-JRC, 2010)
Chemical Wood Pulp	1656	4.504642857	
Dissolving Wood Pulp	1667	5.65	
Other fibreboard	1650	1.699642857	
Mechanical Wood Pulp	1654	2.499642857	
Sawnwood, non-coniferous all	1633	1.875357143	
Particle Board	1697	1.504642857	
Plywood	1640	2.212803571	

Semi-Chemical Wood Pulp	1655	2.671071429	
Veneer Sheets	1634	2.212803571	
Pellets	1693	2.346	(JWEE, 2021)
Briquettes and other agglomerates	1694	2.292	
Recovered Paper	1669	1.526	(Jochem et al., 2021)

Table 11 Wood flow amounts in EU27 for 2021 in Mm³ SWE

Source ID	Target ID	Amounts
Fuelwood:EU	Fuelwood:Export	0.91094
Roundwood:EU	Fuelwood:EU	176.304
Industrial_roundwood:Import	Industrial_roundwood:EU	2.76125
Roundwood:EU	Industrial_roundwood:EU	388.61069
Sawmill:EU	Sawmill:Export	37.99301
Industrial_roundwood:EU	Sawmill:EU	208.13296
Industrial_roundwood:EU	Wood_panel:EU	42.56785
Recovered_post_consumer_wood:EU	Wood_panel:EU	23.00445
Residues:EU	Wood_panel:EU	33.17982
Industrial_roundwood:EU	Pulp_and_wood_pulp:EU	120.81504
Residues:EU	Pulp_and_wood_pulp:EU	38.18948
Chemical_pulp:Import	Chemical_pulp:EU	9.1004
Pulp_and_wood_pulp:EU	Chemical_pulp:EU	127.2496
Mechanical_pulp:EU	Mechanical_pulp:Export	0.60266
Pulp_and_wood_pulp:EU	Mechanical_pulp:EU	21.47774
Dissolving_pulp:EU	Dissolving_pulp:Export	3.40875
Pulp_and_wood_pulp:EU	Dissolving_pulp:EU	10.27717
Plywood:Import	Plywood:EU	4.67106
Wood_panel:EU	Plywood:EU	11.16451
OSB:EU	OSB:Export	1.57854
Wood_panel:EU	OSB:EU	10.78173
MDF_HDF:EU	MDF_HDF:Export	4.52736

Wood_panel:EU	MDF_HDF:EU	24.98633
Particle_board:EU	Particle_board:Export	2.87862
Wood_panel:EU	Particle_board:EU	46.94314
Fiberboard:Import	Fiberboard:EU	0.78888
Wood_panel:EU	Fiberboard:EU	4.87642
Paper_and_board:EU	Paper_and_board:Export	24.12442
Paper_and_board_industry:EU	Paper_and_board:EU	136.4602 1
Recovered_paper:Import	Recovered_paper:EU	0.10405
Paper_and_board:EU	Recovered_paper:EU	66.44012
Pellets:Import	Pellets:EU	3.14149
Pellets:EU	Bioenergy:EU	50.5791
Recovered_post_consumer_wood:EU	Bioenergy:EU	24.66
Fuelwood:EU	Bioenergy:EU	168.8177 8
Sawmill:EU	Sawnwood:EU	93.57698
Sawmill:EU	Residues:EU	76.56298
Chemical_pulp:EU	Paper_and_board_industry:EU	64.0845
Chemical_pulp:EU	Black_liquor:EU	72.2655
Dissolving_pulp:EU	Textiles_Chemicals:EU	2.61
Dissolving_pulp:EU	Black_liquor:EU	4.25843
Mechanical_pulp:EU	Paper_and_board_industry:EU	20.12358
Mechanical_pulp:EU	Black_liquor:EU	0.7515
Plywood:EU	Residues:EU	8.70956
Plywood:EU	Furniture:EU	2.74077
Plywood:EU	Construction_primary:EU	3.65436
Plywood:EU	Packaging:EU	0.73087
OSB:EU	Residues:EU	0.46016
OSB:EU	Furniture:EU	0.28823
OSB:EU	Construction_primary:EU	7.87834
OSB:EU	Packaging:EU	0.57646
Particle_board:EU	Residues:EU	2.20323
Particle_board:EU	Furniture:EU	28.05597
Particle_board:EU	Construction_secondary:EU	12.91465

Particle_board:EU	Packaging:EU	0.89067
MDF_HDF:EU	Residues:EU	1.02295
MDF_HDF:EU	Furniture:EU	11.92665
MDF_HDF:EU	Construction_secondary:EU	5.96333
MDF_HDF:EU	Packaging:EU	1.54605
Fiberboard:EU	Residues:EU	0.28326
Fiberboard:EU	Furniture:EU	0.75537
Fiberboard:EU	Construction_secondary:EU	3.39918
Fiberboard:EU	Packaging:EU	1.22748
Sawnwood:EU	Construction_primary:EU	60.91861
Sawnwood:EU	Construction_secondary:EU	8.5155
Sawnwood:EU	Residues:EU	0.37431
Sawnwood:EU	Packaging:EU	19.83832
Sawnwood:EU	Furniture:EU	3.93023
Construction_primary:EU	Landfill:EU	23.90893
Construction_primary:EU	Recovered_post_consumer_wood:EU	14.49026
Construction_primary:EU	Incineration:EU	3.62257
Construction_primary:EU	Stock_wood:EU	30.42955
Construction_secondary:EU	Landfill:EU	10.16158
Construction_secondary:EU	Recovered_post_consumer_wood:EU	6.15853
Construction_secondary:EU	Incineration:EU	1.53963
Construction_secondary:EU	Stock_wood:EU	12.93292
Furniture:EU	Landfill:EU	15.74009
Furniture:EU	Recovered_post_consumer_wood:EU	9.53945
Furniture:EU	Incineration:EU	2.38486
Furniture:EU	Stock_wood:EU	20.03284
Packaging:EU	Recovered_post_consumer_wood:EU	8.3113
Packaging:EU	Stock_wood:EU	16.49855
Textiles_Chemicals:EU	Landfill:EU	0.8613
Textiles_Chemicals:EU	Incineration:EU	1.7487
Black_liquor:EU	Bioenergy:EU	77.27543

Recovered_paper:EU	Paper_and_board_industry:EU	66.54417
Paper_and_board:EU	Incineration:EU	3.12091
Paper_and_board:EU	Bioenergy:EU	4.49778
Paper_and_board:EU	Landfill:EU	30.19935
Paper_and_board:EU	Stock_paper:EU	8.07764
Residues:EU	Pellets:EU	18.24715
Recovered_post_consumer_wood:EU	Pellets:EU	1.01158
Fuelwood:EU	Pellets:EU	6.57528
Industrial_roundwood:EU	VP_Industrial_roundwood:EU	19.85608
Paper_and_board_industry:EU	VP_Paper_and_board_industry:EU	14.29204
VP_Recovered_post_consumer_wood:EU	Recovered_post_consumer_wood:EU	10.1765
VP_Pellets:EU	Pellets:EU	21.60359

Table 12 Results for 2021. Process inputs and outputs in Mm³ SWE

	Process ID	Input	Output
0	Roundwood:EU	0	564.9147
1	Fuelwood:EU	176.304	176.304
2	Industrial_roundwood:EU	391.3719	391.3719
7	Residues:EU	89.61645	89.61645
3	Sawmill:EU	208.133	208.133
4	Sawnwood:EU	93.57698	93.57698
5	Pulp_and_wood_pulp:EU	159.0045	159.0045
6	Wood_panel:EU	98.75213	98.75213
8	OSB:EU	10.78173	10.78173
9	Particle_board:EU	46.94314	46.94314
10	MDF_HDF:EU	24.98633	24.98633
11	Fiberboard:EU	5.6653	5.6653
12	Plywood:EU	15.83557	15.83557
13	Chemical_pulp:EU	136.35	136.35
14	Dissolving_pulp:EU	10.27717	10.27717
15	Construction_primary:EU	72.45131	72.45131

16	Construction_secondary:EU	30.79266	30.79266
17	Furniture:EU	47.69723	47.69723
18	Bioenergy:EU	325.8301	0
19	Textiles_Chemicals:EU	2.61	2.61
25	Paper_and_board_industry:EU	150.7523	150.7523
21	Landfill:EU	80.87125	0
22	Incineration:EU	12.41667	0
24	Recovered_post_consumer_wood:EU	48.67604	48.67604
20	Paper_and_board:EU	136.4602	136.4602
23	Recovered_paper:EU	66.54417	66.54417
26	Black_liquor:EU	77.27543	77.27543
27	Mechanical_pulp:EU	21.47774	21.47774
	Industrial_roundwood:Import	0	2.76125
	Recovered_paper:Import	0	0.10405
	Fuelwood:Import	0	0
	Paper_and_board:Import	0	0
	OSB:Import	0	0
	Particle_board:Import	0	0
	MDF_HDF:Import	0	0
	Fiberboard:Import	0	0.78888
	Plywood:Import	0	4.67106
	Textiles_Chemicals:Import	0	0
	Sawmill:Import	0	0
	Chemical_pulp:Import	0	9.1004
	Dissolving_pulp:Import	0	0
	Mechanical_pulp:Import	0	0
	Industrial_roundwood:Export	0	0
	Recovered_paper:Export	0	0
	Fuelwood:Export	0.91094	0
	Paper_and_board:Export	24.12442	0
	OSB:Export	1.57854	0
	Particle_board:Export	2.87862	0

D4.1 Material flow analysis results



	MDF_HDF:Export	4.52736	0
	Fiberboard:Export	0	0
	Plywood:Export	0	0
	Textiles_Chemicals:Export	0	0
	Sawmill:Export	37.99301	0
	Chemical_pulp:Export	0	0
	Dissolving_pulp:Export	3.40875	0
	Mechanical_pulp:Export	0.60266	0
	Pellets:Import	0	3.14149
28	Pellets:EU	50.5791	50.5791
29	Packaging:EU	24.80985	24.80985
	Stock_wood:EU	79.89386	0
	Stock_paper:EU	8.07764	0
	VP_Industrial_roundwood:EU	19.85608	0
	VP_Paper_and_board_industry:EU	14.29204	0
	VP_Recovered_post_consumer_wood:EU	0	10.1765
	VP_Pellets:EU	0	21.60359

Table 13 Our MFA results and JRC wood flows results for 2017 on Mm³ SWE. Comparisons should be made with caution given that the methodologies used are not identical.

Resource	Our results for 2021			JRC (2017)			Mantau (2010)		
	Material flow amounts (Mm ³)	Share of total (%)	Including residues and recycled wood (Mm ³)	Material flow amounts (Mm ³)	Share of total (%)	Including residues and recycled wood (Mm ³)	Material flow amounts (Mm ³)	Share of total (%)	Including residues and recycled wood (Mm ³)
Roundwood									
Roundwood total	565			539			577.10		
<i>Industrial roundwood</i>	391	69%		363	67%		368.40	64%	
<i>Fuelwood</i>	176	31%		188	35%		208.80	36%	
Industrial roundwood imbalance									
<i>Mass balance</i>	19.9	4%							
1st transformation									
Semi-finished total (inputs)	371.70		465.89	363		451	368.40		456.70
<i>Sawmill</i>	208.13	56%	208.13	195	54%	195	260.60		314.90
<i>Wood panels</i>	42.57	11%	98.75	51	14%	100			
<i>Residues</i>	33.18			34					
<i>Recovered post-consumer wood</i>	23			15					
<i>Pulp</i>	121	33%	159.00	117	32%	156	107.80	29%	141.80
<i>Residues</i>	38.20			39					
Total residues of the consumed resources (as outputs)	166.89	36%		172	35%		176.30	39%	
<i>from semi-finished products</i>	153.83			159			157.20		
<i>from finished products (recycl/post-cons wood)</i>	13.05			13			19.10		
Total residues of the consumed resources (as inputs)	85.90			88.00			72.80		

D4.1 Material flow analysis results



<i>Panels residues (input)</i>	33.18			34.00			38.80		
<i>Panels residues (input recycling/recovered post-cons material)</i>	23.00			15.00					
<i>Pulp residues (input)</i>	38.20			39.00			34.00		
2nd transformation									
Total end uses (paper and wood products)	286.36			364.00			354.30		
Product stock paper	8.08			136.00			185.20		
Product stock wood	79.89	182		165.00			169.10		
Recovered paper	66.54			63.00					
Share of end uses compared to total roundwood			66%		68%				
Total end uses (bioenergy)	345.76			382.00			337.20		
Bioenergy from industries total	116.67	34%		132.00	35%		103.70	31%	
<i>Other residues (from industry)</i>	14.74	4%		38.00	10%				
<i>Recovered-post consumer wood</i>	24.66	7%		23.00	6%				
<i>By products (black liquor)</i>	77.28	22%		71.00	19%		59.80	18%	
Net trade									
<i>Export</i>	76.83			61.00					
<i>Import</i>	20.54			32.00					

